

Cap Screw Counterbores Multi-Tool System

Forward Counterbore Set

OPERATION FOR FORWARD AND BACKWARD APPLICATIONS

- STEP 1: Select appropriate pilot holder and blade for screw size needed
- STEP 2: Insert blade into pilot holder and tighten set screw
 - A) FORWARD COUNTERBORING: Use in clockwise direction
 - B) BACKWARD COUNTERBORING: Use in reverse spindle, counter-clockwise direction

STEP 1

STEP 2

**FORWARD CUTTING
CLOCKWISE**

**BACKWARD CUTTING
COUNTER-CLOCKWISE**
(Requires reverse spindle drive)

- Simple design for standard cap screws
- More chip clearance
- Used in confined areas
- Using the same pilot holder you can forward counterbore or backward counterbore and spotface

Description	Code
SETS – 10 Pieces – One blade and one pilot holder for screw sizes No. 10, 1/4", 5/16", 3/8", and 1/2"	311031

UPDATED SINCE PRINT CATALOG

Countersinks – 3 Flute

Metric & Inch – Cobalt M35, TiN Coated & Carbide



This highly productive countersinking cutter is a much improved version of the traditional multiflute milling cutter:

- wide flutes provide good chip evacuation
- positive cut
- constant profile aids regrinding of the tool
- self-centering of the cutting mill (three bearing points)
- virtually eliminates vibration

Dimensions are adapted so as to sink 90 degree screw caps up to M12. We recommend lubricating.

Carbide:

Diameter 12.4 to 31 = 3 flatted shanks
 Diameter 4.3 to 8.3 = cylindrical shank
 Diameter 10.4 to 31 = brazed carbide head

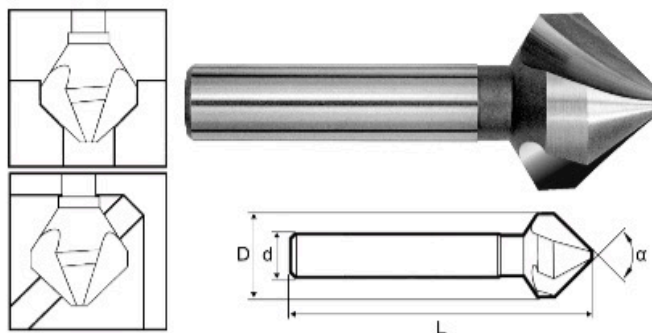

Metric & Inch – Cobalt M35 & TiN Coated – 60°, 82°, 90°, 100°, & 120° Angles

D Overall Diameter (mm)	d Shank Diameter (mm)	Chamfer Range Min/Max (mm)	L Overall Length (Inch)	60° Angle	82° Angle	82° Angle	90° Angle	90° Angle	100° Angle	120° Angle
				Series 432	Series 434	Series 4834 - TiN	Series 431	Series 4831 - TiN	Series 435	Series 433
				Code	Code	Code	Code	Code	Code	Code
6.35 1/4 Inch	6.35	1.5-6.35	1.77		540390	540437	540376	540383		
7.93 5/16 Inch	6.35	2-7.93	1.77		540391	540438	540377	540384		
9.52 3/8 Inch	6.35	2.5-9.52	1.97		540392	540439	540378	540385		
10.4	6	2.5-10.4	2	540301	540311	540361	540321	540371	540331	540341
12.7 1/2 Inch	6.35	2.9-12.7	1.97		540393	540440	540379	540386		
15.87 5/8 Inch	9.52	3.2-15.87	2.36		540394	540441	540380	540387		
16.5	10	3.2-16.5	2-1/4	540302	540312	540362	540322	540372	540332	540342
19.05 3/4 Inch	9.52	3.5-19.05	2.36		540395	540442	540381	540388		
20.5	10	3.5-20.5	2-1/2	540303	540313	540363	540323	540373	540333	540343
25.0	10	3.8-25	2-5/8	540304	540314	540364	540324	540374	540334	540344
25.4 1 Inch	9.52	3.8-25.4	2.76		540396	540443	540382	540389		
31.0	12	4.2-31	2-3/4	540305	540315	540365	540325	540375	540335	540345
40.0	16	8-40	4-1/2	-	-	-	*540326	-	-	-
50.0	16	10-50	5	-	-	-	*540327	-	-	-
63.0	16	10-63	5-1/2	-	-	-	*540328	-	-	-
80.0	16	14-80	6-1/2	-	-	-	*540329	-	-	-

* Three gripping flats on shank

FLAT HEAD SCREWS 82° = SAE (UNF, UNC) 90° = Metric 100° = Aviation