

Electronic Chamfer Gage

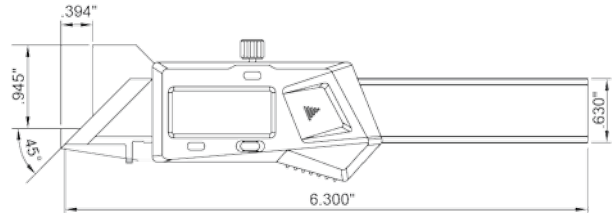

- Measure 45° chamfer dimension
- Resolution: 0.0005"/0.01mm
- Buttons: on/off, set, inch/mm, preset (+, -)
- Auto power off - move unit to turn power on
- Battery CR2032
- Data output
- Stainless steel

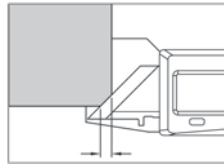

OPTIONAL ACCESSORY: SPC cable

Accuracy (Inch)	INSIZE No.	Code
±0.0025	1180-6	816370

Electronic Radius Gage

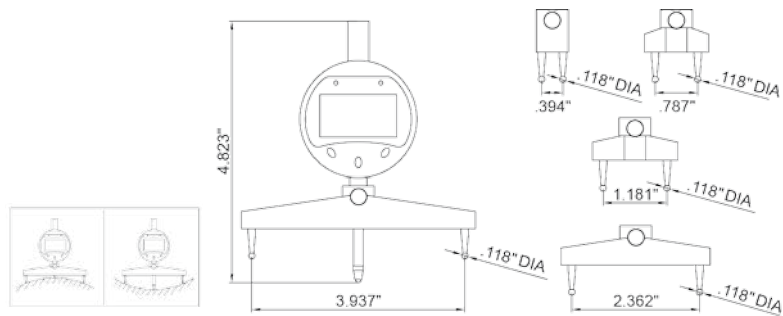

- For measuring the radius of internal and external arcs
- Resolution: 0.00005"/0.005mm
- Supplied with 5 separate jaws for multiple arc sizes
- Battery CR2032
- Supplied in fitted storage case

R Range of Radius (Inch/mm)	Accuracy (Inch)	INSIZE No.	Code
0.2-27.5/5-700	*±0.01R	2183	283213

*R is the radius to be measured (Inch)

Radius Gages



- Supplied in storage pouch



Range	Accuracy	Blade Size	Blade Quantity Internal + External	INSIZE No.	Code
1/32"-1/4"	±0.0012"	1/32, 3/64, 1/16, 5/64, 3/32, 7/64, 1/8, 9/64, 5/32, 11/64, 3/16, 13/64, 7/32, 15/64, 1/4"	15 + 15	4801-15E	283567
17/64"-1/2"	±0.0014"	17/64, 9/32, 19/64, 5/16, 21/64, 11/32, 23/64, 3/8, 25/64, 13/32, 27/64, 7/16, 29/64, 15/32, 31/64, 1/2"	16 + 16	4801-16E	283568