

Pitch Gages



- For measuring the pitch of screw threads
- Blades individually marked with pitch
- Supplied in storage pouch



Range	Accuracy (Inch)	Thread Type	Blade Pitch	No. of Blades	INSIZE No.	Code
1-12 TPI	±0.0028	ACME 29°	1, 1-1/3, 1-1/2, 1-3/4, 2, 2-1/2, 3, 3-1/2, 4, 5, 6, 7, 8, 9, 10, 12 TPI	16	4824-16	283549
2-20 mm	±0.0028	Tr 30°	2, 3, 4, 5, 6, 7, 8, 9, 10, 12, 16, 20 mm	12	4824-12	283548

Pitch Gages Metric & Unified



- For measuring the pitch of screw threads
- Blades individually marked with pitch
- Medium carbon steel
- Supplied in storage pouch



Range	Accuracy (Inch)	Thread Type	Blade Pitch	No. of Blades	INSIZE No.	Code
4-42TPI	±0.0028	Unified 60°	4, 4-1/2, 5, 5-1/2, 6, 7, 8, 9, 10, 11, 11-1/2, 12, 13, 14, 15, 16, 18, 20, 22, 24, 26, 27, 28, 30, 32, 34, 36, 38, 40, 42 TPI	30	4820-230	283552
0.25-7mm	±0.0028	Metric 60°	0.25, 0.3, 0.35, 0.4, 0.5, 0.7, 0.75, 0.8, 0.9, 1, 1.25, 1.5, 1.75, 2, 2.5, 3, 3.5, 4, 4.5, 5, 5.5, 6, 6.5, 7 mm	24	4820-124	283551
0.4-7mm	±0.0028	Metric 60°	0.4, 0.5, 0.6, 0.7, 0.75, 0.8, 0.9, 1, 1.29, 1.5, 1.75, 2, 2.5, 3, 3.5, 4, 4.5, 5, 5.5, 6, 6.5, 7 mm	52	4820-552	816695
4-42TPI		Unified 60°	4, 4-1/2, 5, 5-1/2, 6, 7, 8, 9, 10, 11, 11-1/2, 12, 13, 14, 15, 16, 18, 20, 22, 24, 26, 27, 28, 30, 32, 34, 36, 38, 40, 42 TPI			

Thread Gage



- Standard for grinding and setting tools when cutting ACME threads
- Supplied in storage pouch

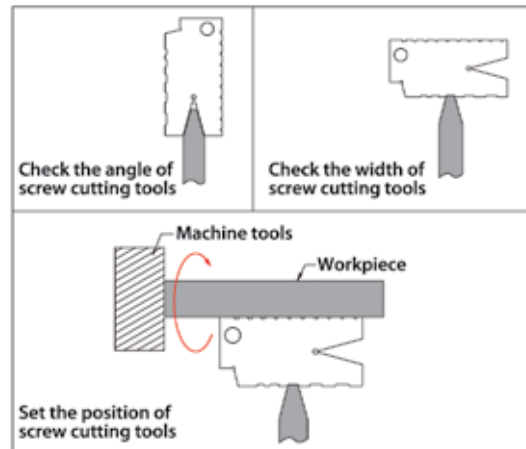
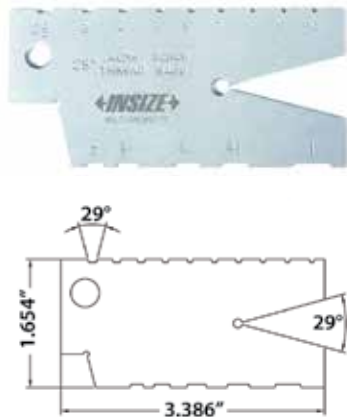

Range	Accuracy	Thread Type	Pitch	INSIZE No.	Code
1-10TPI	±10min.	ACME 29°	1, 1-1/3, 1-1/2, 1-3/4, 2, 2-1/2, 3, 4, 5, 6, 7, 8, 9, 10 TPI	4812-E	283557