

Electronic Height Gages



280759



280757

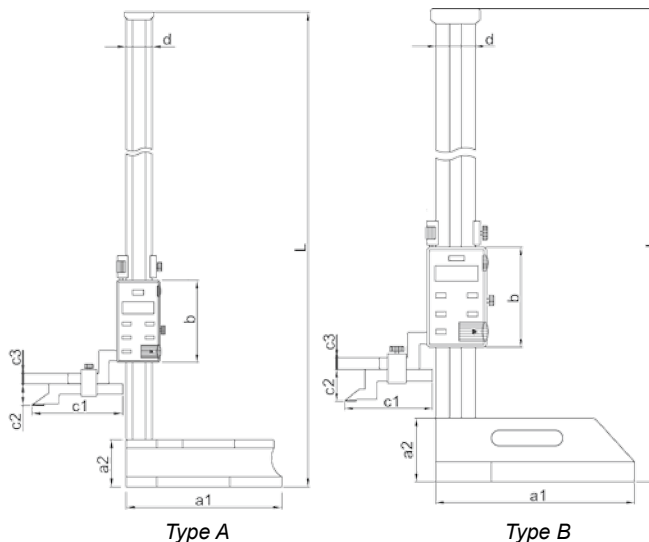

- Resolution: 0.0005"/0.01mm
- Buttons: on/off, zero, inch/mm, ABS/INC (absolute and incremental measurements), data hold, TOL (tolerance measurement), set
- Carbide-tipped scriber, stainless steel beam
- Battery LR44
- Data output
- Supplied with dial test indicator holder
- Supplied with vinyl dust cover

OPTIONAL ACCESSORY: SPC cable T301-SPC5 (Code 280795)

Range (Inch/mm)	Type	Accuracy (Inch)	L (Inch)	a1 (Inch)	a2 (Inch)	b (Inch)	c1 (Inch)	c2 (Inch)	c3 (Inch)	d (Inch)	e (Inch)	f (Inch)	INSIZE No.	Code
0-12/0-300	A	±0.0016	18.504	5.315	1.772	3.150	2.992	0.984	0.394	0.906	0.236	0.315	1150-300E	280756
0-20/0-500	A	±0.0020	28.346	7.087	2.165	3.740	4.055	0.984	0.472	1.181	0.394	0.472	1150-500E	280757
0-24/0-600	B	±0.0020	32.283	7.087	2.165	3.740	4.055	0.984	0.472	1.181	0.394	0.472	1150-600E	280758
0-40/0-1000	B	±0.0028	50.197	9.843	3.150	4.921	4.331	1.535	0.591	1.969	0.394	0.591	1150-1000E	280759

Sizes available up to 80"

Electronic Height Gages



With Drive Wheel

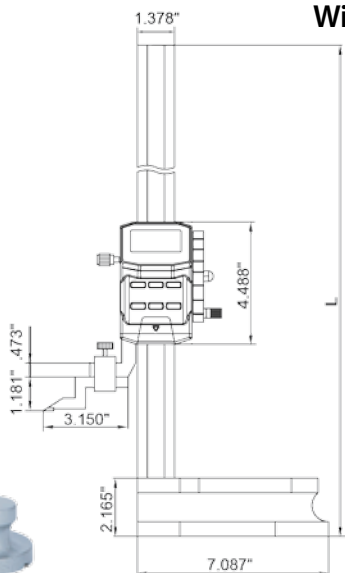

- Resolution: 0.0005"/0.01mm
- Buttons: on/off, zero, inch/mm, preset +, preset -, hold
- Auto power off - move unit to turn power on
- Carbide-tipped scriber, stainless steel beam
- Battery CR2032
- Data output
- Supplied with vinyl dust cover

OPTIONAL ACCESSORIES: SPC cable, Dial Test Indicator Holder

Range (Inch/mm)	Accuracy (Inch)	L (Inch)	INSIZE No.	Code
0-12/0-300	±0.0012	20.276	1156-300	816634
0-24/0-600	±0.0020	32.867	1156-600	816635