

## Centerless Punch Grinders

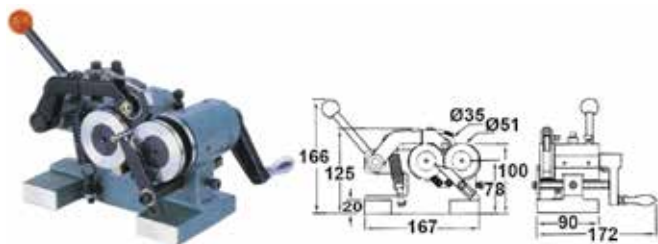

- High accuracy
- Centerless - no alignment necessary
- Rollers accept 0.06" – 1" diameters

Model	Weight	Code
PGA	5.5 kg	302470

### Motorized

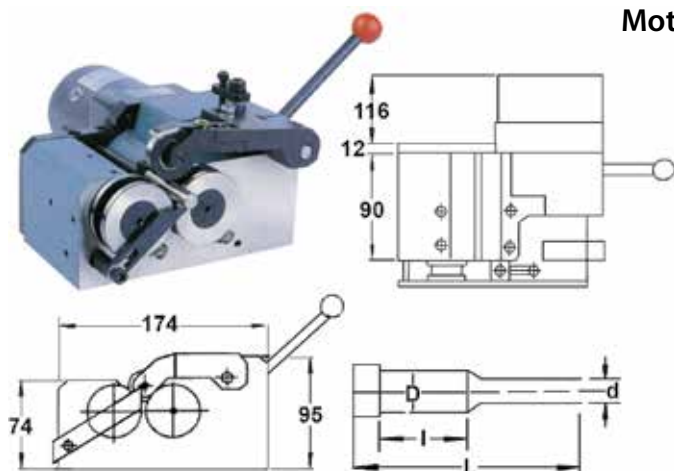

- Motor 110V, 25 watts
- Roller speed: 130 RPM
- D: 1.5-25mm
- d: 0.5-25mm
- L: maximum 120mm
- l: minimum 22mm

Model	Weight	Code
PGAM	11.5 kg	302471

## Punch Formers

### Tangential Style

#### Double Offset

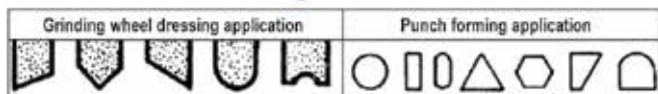

- Maximum diameter of workpiece: 32mm (1-1/4")
- V-Block: 30mm (1-3/16")
- Tangential travel: 20mm (25/32") either side of center
- V-Block adjusting system: rack and pinion
- Center height at 80mm (or 3-1/2")
- Indexing div: 24 (every 15°) ±10 seconds
- Angle setting: by sine system - gage blocks
- Roundness: 0.002mm (0.0001")
- Parallelism: within 0.005mm/50mm (0.0002 in 2")
- Squareness: within 0.005mm/50mm (0.0002 in 2")
- Construction: hardened tool steel throughout for long and accurate life
- Weight: 10 kgs (22 lbs.)

Code
875440

#### Single Offset

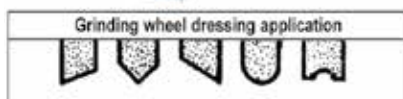

- Concentricity: within 0.003mm (0.0001")
- 24 index divisions (increments DF15°) within ±10 seconds
- Capacity: 32mm (1-1/4"), 90° V-blocks
- 30mm (1-1/8") through center hole
- Squareness and parallelism to within ±0.003 mm (±0.0001")
- Weight: 7.7 kg (17 lbs)

Code
865415