

Super Indexing Spacers

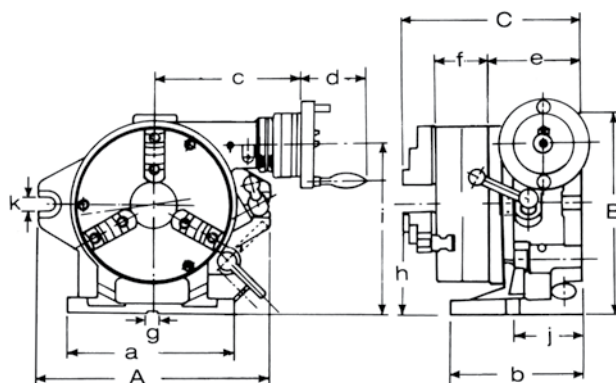

Masking Plates

Model	Chuck				Face Plate	
	Outer Diameter (mm)	Inner Jaw (mm)	Outer Jaw (mm)	Inner Diameter (mm)	Outer Diameter (mm)	Thickness (mm)
CS-6	160	4-42	10-156	44	203	50
CS-8	210	4-62	10-180	63	254	58

- 3-jaw chuck mounted
- In addition to all of the features of the simple indexing spacer, the super indexing spacer incorporates a worm gear and is supplied with a face plate. With the further addition of the optional dividing plate set, it can also be used as a dividing head.
- The worm gear is hardened and precision ground to minimize wear

Dividable Number	A (mm)	B (mm)	C (mm)	a (mm)	b (mm)	c (mm)	d (mm)	e (mm)	f (mm)	g (mm)	h (mm)	i (mm)	j (mm)	k (mm)	Weight (kg)	Code
2, 3, 4, 6, 8, 12, 24	250	235	221	220	150	184	82	112	66	16	123	186	80	18	43.6	277088
2, 3, 4, 6, 8, 12, 24	310	285	243	225	160	201	82	125	75	16	155	232	90	18	78.3	277090

Dividing Plate Sets

- Set includes: indexing plate, crank handle, screws (3), sector and a "U" washer



DP-1



DP-2, DP-3, DP-4, DP-5

Model	Number of Holes	
	Holes	
DP-1	A Plate: 15, 16, 17, 18, 19, 20	
	B Plate: 21, 23, 27, 29, 31, 33	
	C Plate: 37, 39, 41, 43, 47, 49	
DP-2, DP-3, DP-4, DP-5	A Plate: 26, 28, 30, 32, 34, 37, 38, 39, 41, 43, 44, 46, 47, 49, 51, 53, 57, 59	
	B Plate: 61, 63, 67, 69, 71, 73, 77, 79, 81, 83, 87, 89, 91, 93, 97, 99	

Model	Suitable for.....	Weight (kg)	Code
DP-1	HV-4, HV-6, VUT-6, VU-100, VU-150	1.4	277100
DP-2	HV-8, VU-200	4.5	277102
DP-3	HV-10, HV-12, HV-14, HV-16, VUT-10, VUT-12	4.6	277104
DP-4	CS-6, CS-8	4.6	277101
DP-5	VU-300	4.6	277103