

## Face Mill Holders



- Holders have four mounting holes with 5/8-11 thread on a 4" bolt circle to hold 8" or larger face milling cutters
- Holders have 1" drive keys

Taper	Arbor Diameter (Inch)	Arbor Length (Inch)	Weight (lbs)	Code
ISA40	2	6.20	7.5	827162
ISA40	2-1/2	6.20	8.0	827163
ISA50	2	7.56	11.5	827164
ISA50	2-1/2	7.56	11.8	827165

## Boring Head Adapters

For Boring Heads with Threaded Bores – CAT V-Flange Shanks

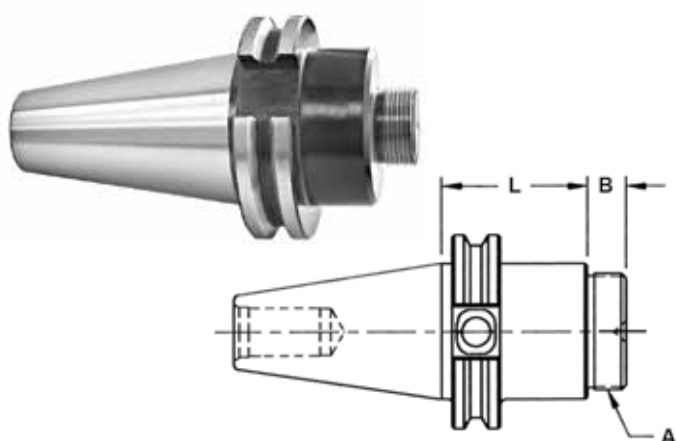

Taper	A Thread	B (Inch)	L (Inch)	Code
CAT40	7/8-20	0.44	1.50	827170
CAT40	1-1/2-18	0.50	2.00	302431
CAT50	1-1/2-18	0.44	1.75	302432

## Centering Plug Arbors

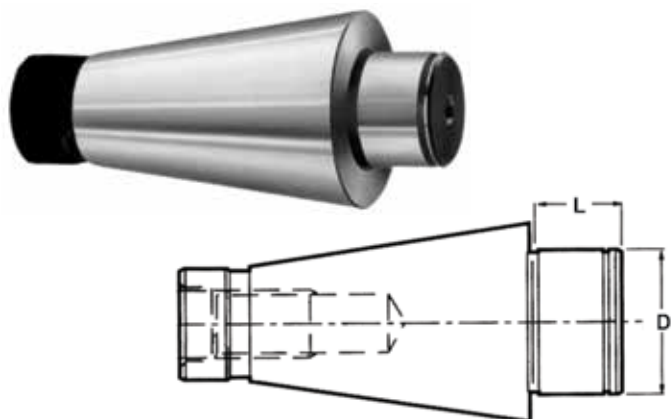

Taper	D (Inch)	L (Inch)	Code
ISA50	2	1-1/4	213530
ISA50	2-1/2	1-1/4	213532