

Blade Holders

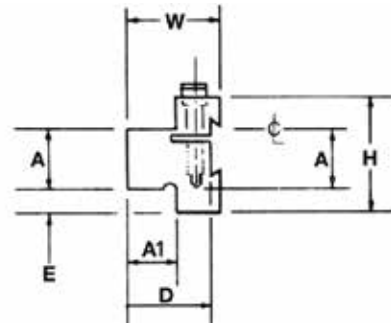

Interchangeable with most popular brands



A (Inch)	A1 (Inch)	D (Inch)	E (Inch)	H (Inch)	W (Inch)	Overall Length (Inch)	Reference Blade	Reference Blade Height Inch (mm)	Code
5/8	5/8	31/32	11/64	1-3/16	1-1/16	3	577049	0.787 (20)	577001
5/8	5/8	1-1/32	7/16	1-1/2	1-3/16	3	577051, 577053, 577055, 577057, 577059	1.020 (26)	577003
3/4	3/4	1-1/8	21/64	1-17/32	1-5/16	3-3/8	577051, 577053, 577055, 577057, 577059	1.020 (26)	577005
3/4	3/4	1-1/8	1/2	1-7/8	1-3/8	4	577061, 577063, 577066, 577067, 577069	1.260 (32)	577011
1	1	1-13/32	5/16	1-7/8	1-5/8	4-3/8	577061, 577063, 577066, 577067, 577069	1.260 (32)	577007
1-1/4	1-1/4	1-11/16	1/8	1-7/8	1-5/8	4-11/16	577061, 577063, 577066, 577067, 577069	1.260 (32)	577009

Blades

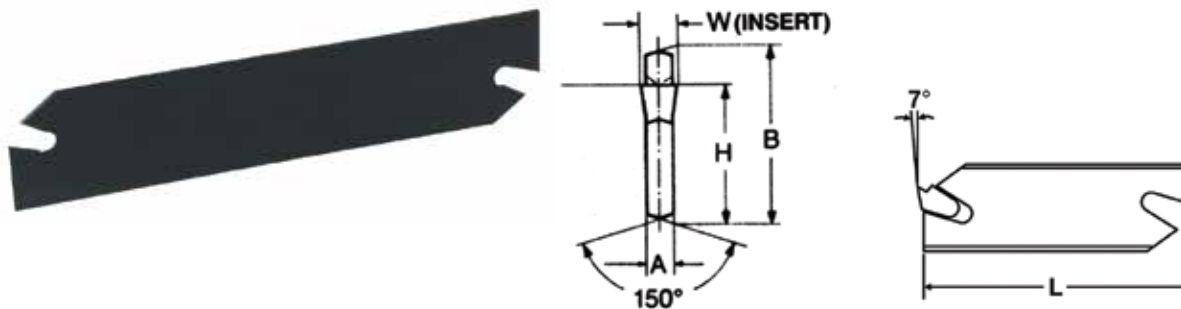

A (Inch)	L (Inch)	H (Inch)	B Inch (mm)	Max Ø (Inch)	Insert Width Reference (Inch)	Model	Code
1/16	3-3/8	39/64	0.787 (20)	1-1/2	0.087 + 0.094	GIH19-2	577049
1/16	4-5/16	53/64	1.020 (26)	2	0.087 + 0.094	GIH26-2	577051
3/32	4-5/16	53/64	1.020 (26)	3	0.120	GIH26-3	577053
1/8	4-5/16	53/64	1.020 (26)	3	0.160	GIH26-4	577055
5/32	4-5/16	53/64	1.020 (26)	4	0.187 + 0.200	GIH26-5	577057
13/64	4-5/16	53/64	1.020 (26)	4	0.250	GIH26-6	577059
3/32	5-7/8	63/64	1.260 (32)	4	0.120	GIH32-3	577061
1/8	5-7/8	63/64	1.260 (32)	4	0.160	GIH32-4	577063
5/32	5-7/8	63/64	1.260 (32)	5	0.187 + 0.200	GIH32-5	577065
13/64	5-7/8	63/64	1.260 (32)	5	0.250	GIH32-6	577067
5/16	5-7/8	63/64	1.260 (32)	5-1/2	0.375	GIH32-9	577069

Inserts

Neutral



Neutral shown



NEUTRAL

CARBIDE GRADES:

C2 - Uncoated for non-ferrous materials

C6 - Uncoated for steel

TIN - TiN coated for steel

Insert Width (Inch)	C2	C6	TIN
	Code	Code	Code
0.087	577071	577073	577075
0.094	577077	577079	577081
0.120	577083	577085	577087
0.160	577089	577091	577093
0.187	577095	577097	577099
0.200	577101	577103	577105
0.250	577107	577109	577111
0.375	577113	577115	577117