

Sine/Angle Dresser

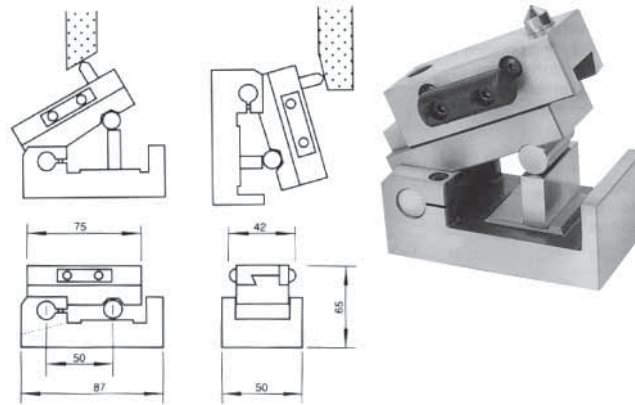

- This fine precision unit dresses grinding wheels to any angle from 0-60 degrees with new smoothness and accuracy
- The unit has a cross feed range up to 2"/50mm
- Roller centers – 2"/50mm

Code
302237

Simple Radius Dresser

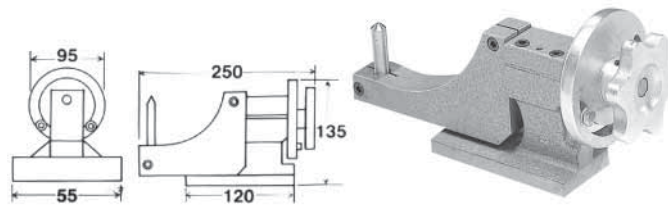

Maximum Radius (Inch/mm)	Code
2/50	302238

Radius and Angle Dresser

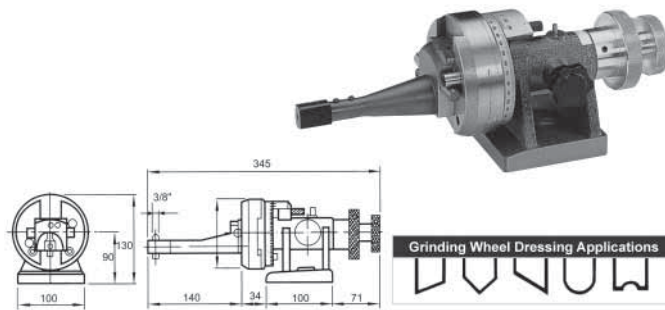

Maximum Diameter of Wheel (Inch)	Convex Radius (Inch)	Concave Radius (Inch)	Tangent Travel Either Side of Center (Inch/mm)	Range of Angle Dressing	Code
10	0-1.18	0.02-1.18	1.18/30	95°-0°-95°	395912